



ZENDURE

The Global Pioneer of Plug-in HEMS



Smart Meter 3CT-S/1CT-S
User Manual

Disclaimer

Read all safety guidelines, warnings and other product information in this manual carefully, and read any labels or stickers attached to the product before using. Users take full responsibility for the safe usage and operation of this product. Familiarize yourself with relevant regulations in your area. You are solely responsible for being aware of all relevant regulations and using Zendure products in a way that is compliant. Keep this manual for future reference.

Contents

| | |
|---|----|
| 1. Safety Instructions | 2 |
| 1.1 Usage | 2 |
| 1.2 EC DECLARATION OF CONFORMITY | 2 |
| 2. Symbols Used in This Guide | 3 |
| 3. What's in the Box | 3 |
| 4. Overview | 4 |
| 4.1 System Overview | 4 |
| 4.2 Product Overview | 5 |
| 4.3 Button Controls | 5 |
| 4.4 LED Display | 6 |
| 5. Installing Your Smart Meter 3CT-S/1CT-S | 6 |
| 5.1 Pre-assembly | 6 |
| 5.2 Identifying Electrical Circuits in the Distribution Box | 7 |
| 5.2.1 Three-Phase Electrical System | 7 |
| 5.2.2 Single-Phase Electrical System | 7 |
| 5.3 Put on Insulating Gloves | 7 |
| 5.4 Turn Off the Power | 7 |
| 5.5 Mounting the Smart Meter 3CT-S/1CT-S | 8 |
| 5.6 Wiring | 8 |
| 5.6.1 Installing the Smart Meter 3CT-S in a Three-Phase Power System | 8 |
| 5.6.2 Installing the Smart Meter 1CT-S in a Single-Phase Power System | 9 |
| 5.7 Internet Connectivity | 11 |
| 5.8 RS485 Communication Connection Guide | 11 |
| 5.8.1 Overview of RS485 Communication Interfaces | 11 |
| 5.8.2 Method 1: RJ45 Port Direct Connection | 11 |
| 5.8.3 Method 2: Bare-Wire Terminal Connection | 12 |
| 5.9 Power On | 13 |
| 6. Zendure App Setup | 13 |
| 6.1 Add Smart Meter 3CT-s/1CT-s | 13 |
| 6.2 Initialization Settings | 14 |
| 6.3 Data Monitoring | 14 |
| 7. Maintenance | 15 |
| 8. Technical Specifications | 15 |

1. Safety Instructions



1.1 Usage

1. We strongly recommend users carefully read the safety regulations and installation instructions, and watch the installation video.
2. The Zendure Smart Meter 3CT-S/1CT-S must be installed by a licensed electrician, who should be familiar with all electrical codes, electrical wiring practices and experienced working with home electrical systems. They possess the necessary knowledge and experience to ensure the safety and accuracy of the installation.
3. During installation, safety Instructions and installation instructions must be followed to ensure all connections are secure and reliable. Please note that careless installation may result in equipment damage, electrical malfunction, or even injury. Therefore, for your own safety and proper device operation, please proceed with caution.
4. Do not install or operate the system under extreme climatic conditions such as lightning, snow, heavy rain, strong winds, etc.
5. Please check whether Smart Meter 3CT-S/1CT-S is damaged, cracked, or cables are damaged before operating. If any, please stop using the product immediately
6. Do not use strong static electricity or magnetic fields.
7. It is prohibited to place the equipment in an environment with flammable, explosive gas, or smoke.
8. Do not attempt to replace the internal components of the equipment by any unauthorized personnel.
9. Ensure that the input power connection is disconnected before installation.
10. Do not install or operate the product outdoors or expose to moisture or submerge it in liquid. Only clean the ports with a dry cloth.
11. Do not install or operate the product in extreme temperatures. Do not dispose of the product in heat or fire.
12. Do not use the product if it is damaged or appears to be damaged. Do not disassemble the product. Consult official Zendure channels when service or repair is required. Incorrect disassembly or reassembly may result in a risk of fire or injury to persons.
13. Adhere to all local and national safety regulations for installation and use.
14. This product is designed for residential use only. Keep out of reach of children and pets.
15. In case of a fire, only a dry powder fire extinguisher is suitable for this product.
16. If the product accidentally falls into water during installation and using, please do not continue installation or use, and contact customer service.





1.2 EC DECLARATION OF CONFORMITY

ZENDURE TECHNOLOGY CO., LIMITED declares that Smart Meter 3CT-S/1CT-S complies with directive 2014/53/EU (RED) , 2011/65/EU(RoHS) , 2015/863/EU(RoHS) .

The full text of the Declaration of Conformity is available at the following web address: <https://zendure.de/pages/download-center>

| | |
|--|--|
|  | <p>Declaration of conformity The EU Declaration of Conformity can be requested at this address: https://zendure.de/pages/download-center</p> |
|  | <p>Disposal and Recycling Disposal of packaging: dispose of the packaging separately by type of material.</p> |
|  | <p>Disposal of old equipment (applies in the European Union and other European countries with separate collection (waste collection) Old equipment must not be disposed of in household waste. Every consumer is legally obligated to dispose of old equipment that can no longer be used separately from household waste, for example at a collection point for recyclables. To ensure proper recycling and avoid negative impact on the environment, electronic devices must be taken to an appropriate collection site. For this reason, electronic devices are marked with the symbol shown to the left.</p> |

2. Symbols Used in This Guide

| Symbol | Explanation |
|--|---|
|  | A high-risk hazard that, if not avoided, could result in death or serious injury. |
|  | Important information that you must pay attention to. |
|  | Included with your product |
|  | Optional (not included) |
|  | Indicates additional information on correct use or useful tips. |

3. What's in the Box

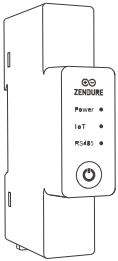

Zendure Smart Meter

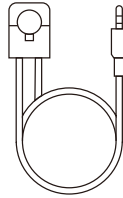

Smart Meter 3CT-S: 3 × 120A Current Transformers (CT)
Smart Meter 1CT-S: 1 × 120A Current Transformer (CT)



User Manual

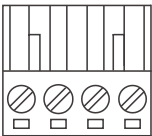

Voltage Input Terminal



Screwdriver

4. Overview

4.1 System Overview

The Zendure Smart Meter 3CT-S/1CT-S is a DIN rail-mounted smart meter that monitors voltage, current, and power data in real-time. It can connect via Ethernet, Wi-Fi, RS485 and Bluetooth to establish connections with other devices and cloud servers, enabling control of operating modes, input/output power, and other functions.

Three-phase power system

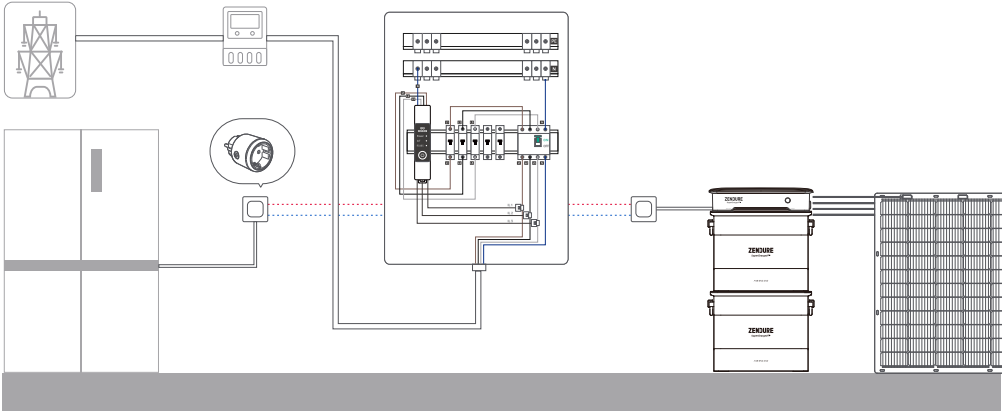

Single-phase power system

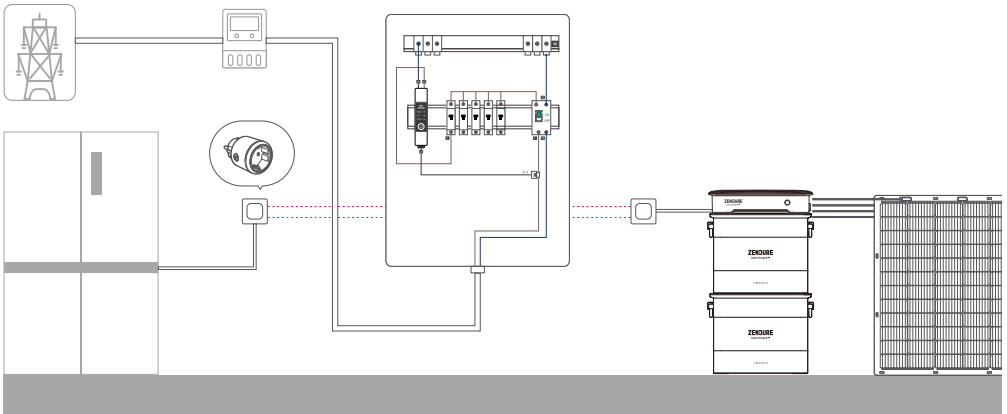

4.2 Product Overview

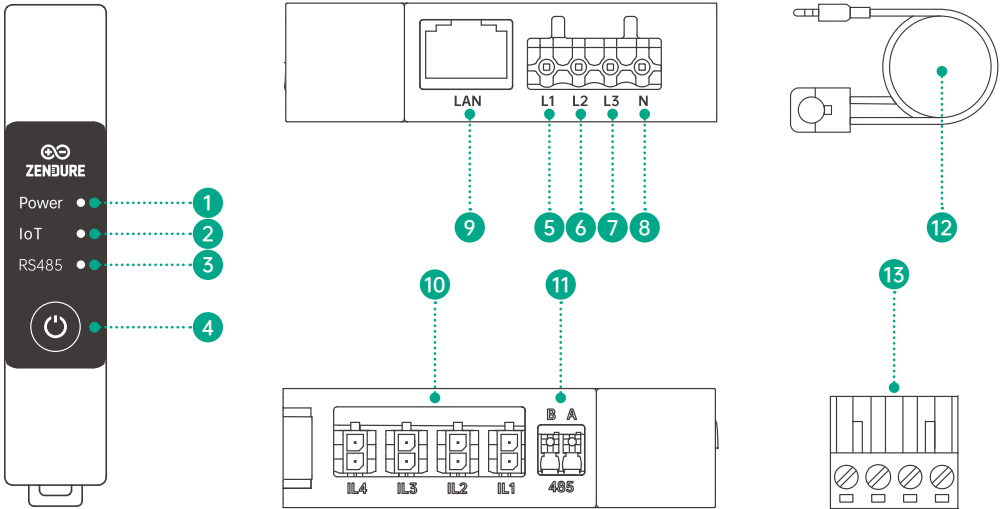

| No. | Term |
|-----|-----------------------------------|
| 1 | Power Status Indicator |
| 2 | IoT Status Indicator |
| 3 | RS485 Status Indicator |
| 4 | Button |
| 5 | Voltage L1 Input |
| 6 | Voltage L2 Input |
| 7 | Voltage L3 Input |
| 8 | Neutral Conductor Input |
| 9 | Combo RJ45 Port for LAN and RS485 |
| 10 | Current Transformer Connector |
| 11 | RS485 Port |
| 12 | Current Transformers |
| 13 | Voltage Input Terminal |

4.3 Button Controls

| Button | Action | Function |
|---|---------------------|----------------------------|
|  | Press for 3 second | Reset the Wi-Fi connection |
| | Press for 10 second | Reset the Smart Meter |

4.4 LED Display

| LED Indicator | LED Description | Detailed Explanation |
|--|---|--|
|  | All LEDs are off | No power |
|  | Solid green power indicator | Power On |
|  | Blinking red power indicator | Device error. Please check the app for details. |
|  | Blinking green IoT indicator | Network disconnected state and waiting to connect to Wi-Fi/LAN |
|  | Solid green IoT indicator | Normal Internet connection |
|  | Solid yellow IoT indicator | Internet connection is interrupted, but local communication is functioning normally. |
|  | Solid red IoT indicator | Internet connection and local communication are both abnormal. |
|  | The three status LEDs on the Power-IoT-RS485 cycle in a running-green pattern | Updating via OTA |

5. Installing Your Smart Meter 3CT-S/1CT-S

5.1 Pre-assembly



1. Important Safety Instructions





- (1) Risk of Electric Shock: The Smart Meter 3CT-S/1CT-S device must be installed by a qualified electrician with caution. Before making any connections, ensure that the circuit is de-energized.
- (2) Connect the device only as described in this manual. Any other method may result in damage or injury.
- (3) Do not place the device where it may get wet.
- (4) Keep the Smart Meter 3CT-S/1CT-S device out of reach of children.

2. Installation Preparation



- (1) Power cables: Need to be purchased separately. It is recommended to use solid single-core cables to connect to the Smart Meter 3CT-S/1CT-S. These cables should have insulation heat resistance and flame retardant properties that comply with European regulations.

5.2 Identifying Electrical Circuits in the Distribution Box

5.2.1 Three-Phase Electrical System

| Wire Type | Color | |
|--------------------------|----------------------|--|
| Live Wire L1 | Brown |  |
| Live Wire L2 | Black |  |
| Live Wire L3 | Gray |  |
| Neutral Wire N | Blue |  |
| Protective Earth Wire PE | Yellow-Green Striped |  |

5.2.2 Single-Phase Electrical System

| Wire Type | Color | |
|--------------------------|----------------------|--|
| Live Wire L | Brown |  |
| Neutral Wire N | Blue |  |
| Protective Earth Wire PE | Yellow-Green Striped |  |

5.3 Put on Insulating Gloves

▲ Note: Not included. To be provided by the electrician/user.

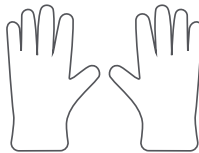

5.4 Turn Off the Power

Before beginning equipment installation, ensure that the power is turned off and there is no voltage at the terminals to avoid electric shock. This can be verified using a multimeter. Once you have confirmed there is no voltage present, you may proceed with the subsequent installation steps.



5.5 Mounting the Smart Meter 3CT-S/1CT-S

- (1) Mount the device in a suitable distribution box or control panel. Ensure there is enough space for wiring and ventilation.
- (2) The device can be mounted on a DIN rail, which is common in most installation control cabinets.

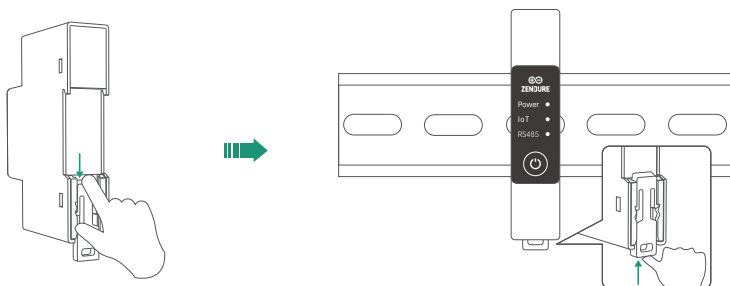

5.6 Wiring

5.6.1 Installing the Smart Meter 3CT-S in a Three-Phase Power System

1. Prepare the power cables: according to the color coding of Live Wire L1/L2/L3 and N wire.
2. Connect the four power cables to the voltage terminal and secure them with a screwdriver.
3. Insert the voltage terminal into the device.

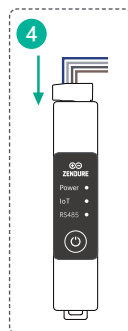
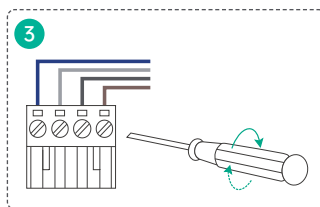
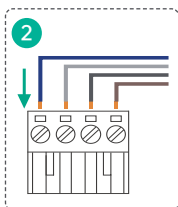
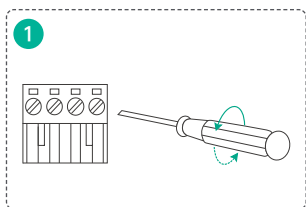

4. Connect the Neutral (N) wire from the meter's voltage terminal to the Neutral busbar in the distribution box.
5. Connect the L1, L2, and L3 phase wires from the meter's voltage terminals to the corresponding terminals of the circuit breaker.

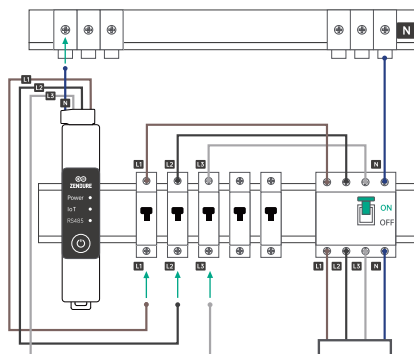

- Connect the CT clamps for phases L1, L2, and L3 sequentially to the CT input terminals (IL1, IL2, and IL3) at the bottom of the device.
- Snap the CT clamps onto the corresponding live wires (L1, L2, L3) at the RCD side, ensuring the arrow on each CT points in the direction of current flow.

▲ Note:

- Directional Alignment:** Each CT clamp is laser-etched with Grid → Home icons. The arrow must align with the energy flow from the utility grid to your household:
 - Grid Side: Points toward the incoming power source (Main Meter/Grid).
 - Home Side: Points toward your domestic distribution panel (Loads). Ensure all three clamps (L1, L2, L3) are installed in this same direction.
- Expandability:** For monitoring dedicated circuits (such as heat pumps or solar inverters), you can purchase an auxiliary CT clamp via zendure official website and connect it to the IL4 port.

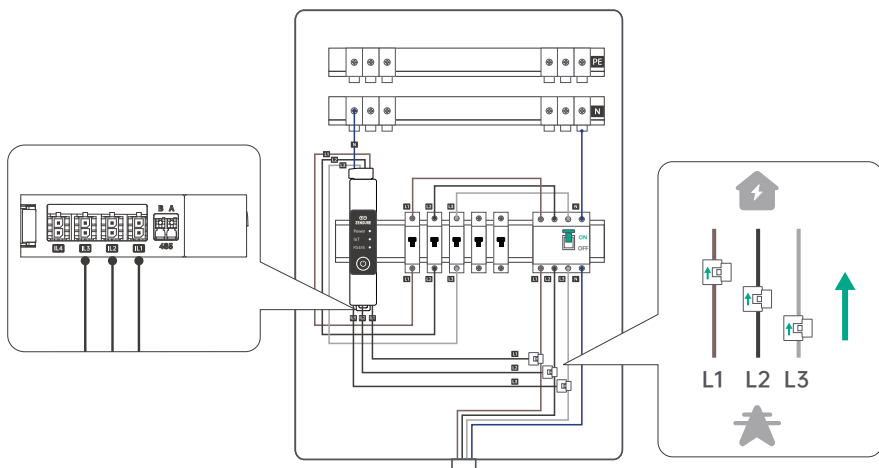

5.6.2 Installing the Smart Meter 1CT-S in a Single-Phase Power System

- Prepare the power cables: according to the color coding of Live Wire L and N wire.
- Connect the two power cables to the voltage terminal(L3, N) and secure them with a screwdriver.
- Insert the voltage input terminal into the device.

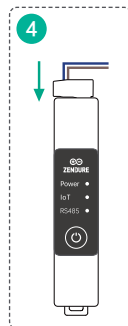
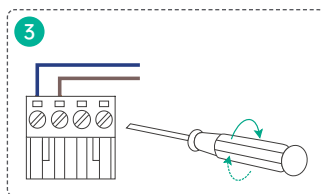
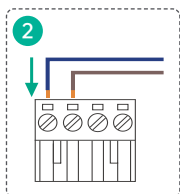
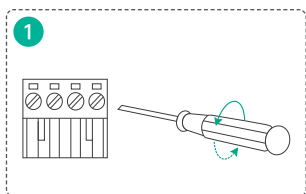

4. Connect the Neutral (N) wire from the meter's voltage terminal to the Neutral busbar in the distribution box.
5. Connect the L wire from the meter's voltage terminals to the corresponding terminals of the circuit breaker.

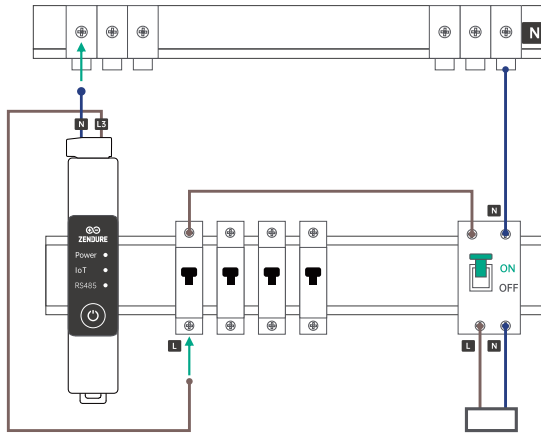

6. Connect the CT clamp to the IL3 CT input terminal at the bottom of the device.
7. Snap the CT clamps onto the corresponding live wire at the RCD side, ensuring the arrow on CT points in the direction of current flow.

⚠ Note:

1. Directional Alignment: CT clamp is laser-etched with Grid → Home icons. The arrow must align with the energy flow from the utility grid to your household:
 - Grid Side: Points toward the incoming power source (Main Meter/Grid).
 - Home Side: Points toward your domestic distribution panel (Loads).
2. Expandability: For monitoring dedicated circuits (such as heat pumps or solar inverters), you can purchase an auxiliary CT clamp via zendure official website and connect it to the IL1/2/4 port.

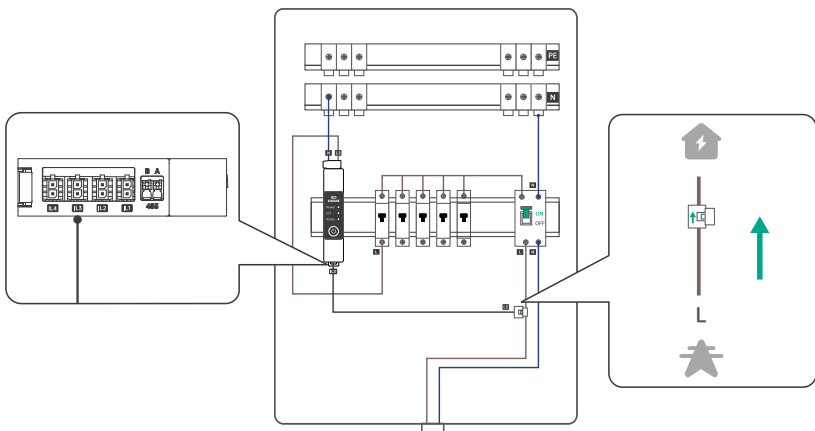

Here is the fully translated and professionally polished English version of the installation manual, tailored to meet international market standards.

5.7 Internet Connectivity

The device supports Internet connectivity via Wi-Fi or LAN. If the signal inside the electrical panel is weak, it is recommended to connect the device directly to the router using an Ethernet cable.

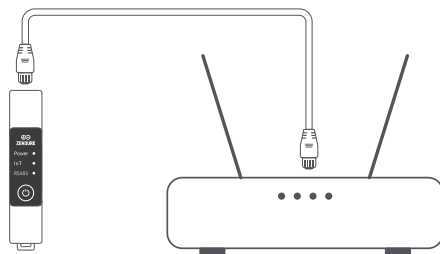

5.8 RS485 Communication Connection Guide

5.8.1 Overview of RS485 Communication Interfaces

This Smart Meter is equipped with two hardware variants for RS485 interfacing. Please select the appropriate RS485 connection method based on your inverter model and hardware version:

1. Method 1: RS485 Communication via Combo RJ45 Port (Plug & Play)
2. Method 2: RS485 Communication via Bare-Wire Terminals (Stripping Required)

5.8.2 Method 1: RJ45 Port Direct Connection

1. Compatible Inverter Models: SolarFlow 4000 Mix Pro, SolarFlow 4000 Mix AC+, and future RS485-compatible products.

2. Installation Steps

- (1) Prepare a standard Ethernet cable of appropriate length
- (2) Plug one end of the cable into the meter's Combo RJ45 Port
- (3) Plug the other end directly into the RS485 port on the inverter

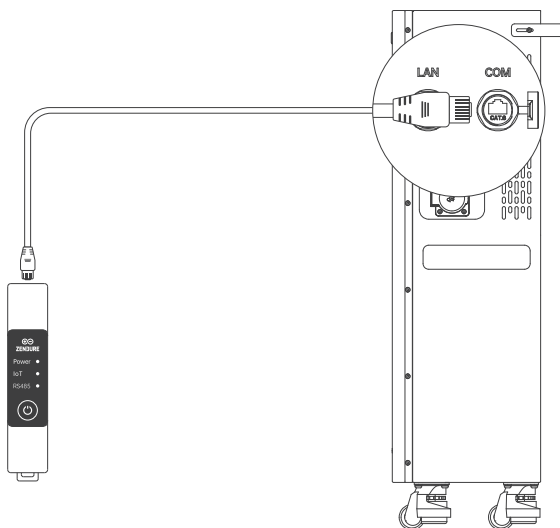

5.8.3 Method 2: Bare-Wire Terminal Connection

1. Compatible Inverter Models: SolarFlow 1600 AC+, SolarFlow 2400 AC+, SolarFlow 2400 Pro
2. RS485 Bare-Wire Terminal and Pin Mapping

| Meter RS485 Terminal | Inverter RJ45 Pin | RS485 Signal Name | Recommended Core Wire Color (T568B Standard) |
|----------------------|-------------------|-------------------|--|
| A (Terminal Slot) | PIN 2 | RS485-A | Orange |
| B (Terminal Slot) | PIN 1 | RS485-B | White-Orange |

3. Installation Steps

- (1) Routing & Cutting: Plug one end of the Ethernet cable into the inverter's RS485 port and route the cable to the meter's wiring area. Cut off the RJ45 connector at the meter end.

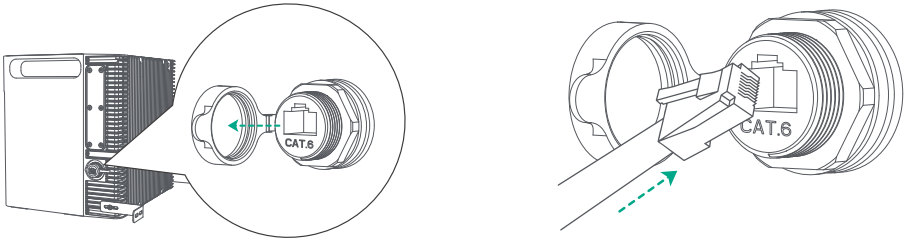

- (2) Jacket Stripping: Use a wire stripper to carefully remove the outer jacket of the cable.
- (3) Wire Selection: Based on the inverter's pin definition, isolate only the orange and white-orange wires corresponding to the RS485 A and B signals. Cut off the remaining unused wires and insulate them properly.
- (4) Core Stripping & Crimping: Strip the insulation layer of these two RS485 core wires to expose the copper conductor. It is highly recommended to crimp them with cord-end terminals (ferrules).

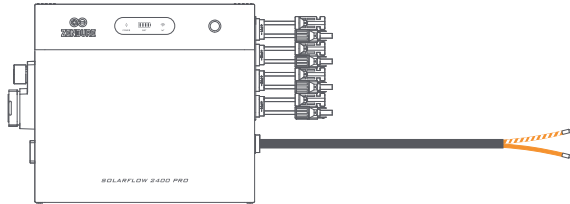

(5) Connecting to Spring-Clamp Terminals

Press and hold the spring terminal with a slotted screwdriver, insert the wire, and release:

- RS485-A Port: Insert the Orange wire.
- RS485-B Port: Insert the White-Orange wire.

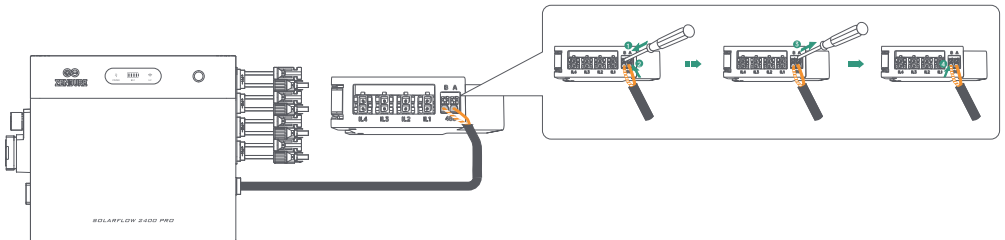

4. Inspection: Gently tug the wires to ensure the RS485 A/B connections are firm and secure.

5.9 Power On

-  Check that all connections are safe and error-free before powering up the device.
Turn on the main circuit breaker of your home electrical system. The Smart Meter 3CT-S/ICT-S will automatically power up, indicated by:

- (1) Power LED: Solid green power indicator
- (2) IoT LED: Blinking, indicating Wi-Fi connection is needed

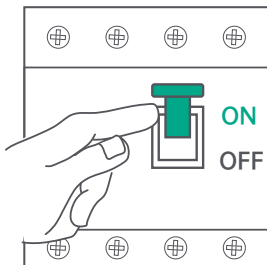

6. Zendure App Setup

6.1 Add Smart Meter 3CT-s/ICT-s

1. Power on the smart meter.
2. Press and hold the IoT button for 3 seconds until the Wi-Fi indicator flashes quickly. The device enters configuration mode.
3. On the Device page, tap "Add Device" or the "+" icon. The app will scan for nearby Zendure devices and please select Smart Meter 3CT-s/ICT-s.
4. Select a proper connection method. Wi-Fi, Ethernet and Bluetooth are supported. Please note that only 2.4 GHz Wi-Fi networks are supported.
5. Smart Meter 3CT-s/ICT-s can be added to a home energy management system to monitor system consumption and provide essential data for storage scheduling.

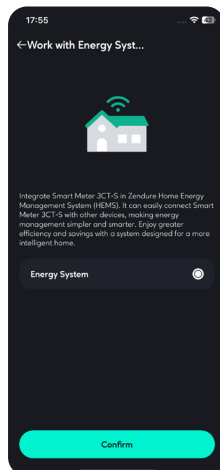
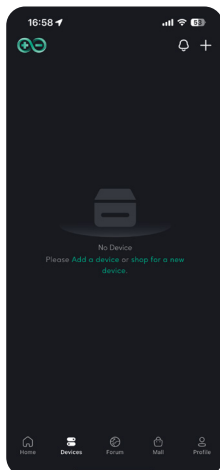
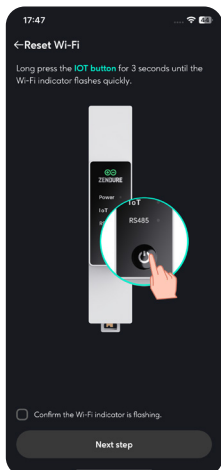

6.2 Initialization Settings

Click the Smart meter in the Device list and finish the initialization settings.

1. Set home electrical system: Single-phase or Three-phase.
2. Set the consumption type monitored by each clamp.
 - (1) Supported consumption type to be monitored: rooftop solar, home usage and heat pump.
 - (2) For a three-phase system, only one additional clamp is available.
 - (3) For a single-phase system, except the main circuit, three additional clamps can be added.

Note: According to the specific system and usage, additional clamps may need to be bought separately. And for a single-phase system, to enable IL1 and IL2 for additional clamps, L1 and L2 should be connected and powered as well.

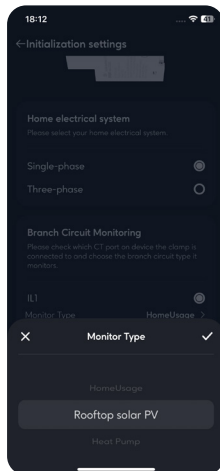
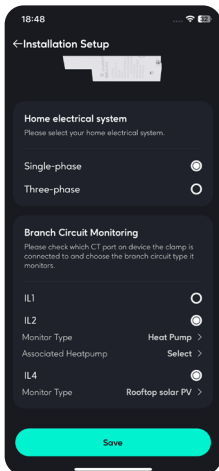
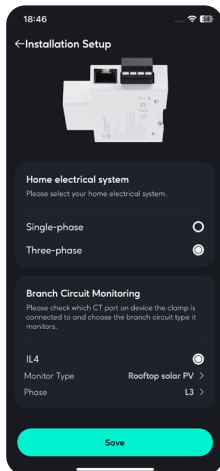
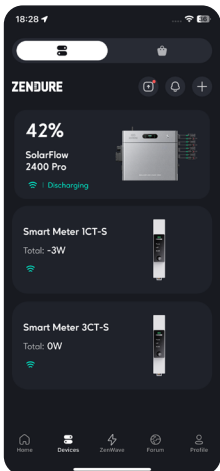

6.3 Data Monitoring

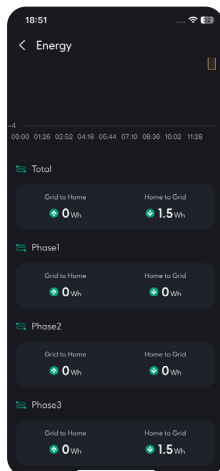
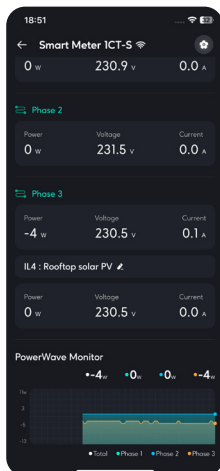
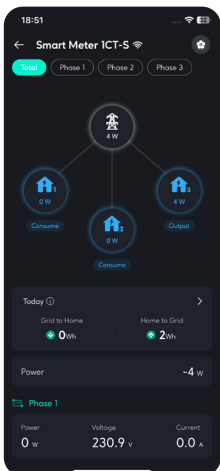

-  1. The Zendure app is continually being improved and may change over time. If there are any differences between the instructions in this guide and in the app, follow the in-app instructions.
2. Privacy Policy: By using Zendure Products, Applications and Services, you consent to the Zendure Terms of Use and Privacy Policy, which you can access via the "About" section of the "User" page in the Zendure app.



The Zendure app allows users to monitor and manage power systems, offering real-time power monitoring, historical records, charge/discharge scheduling, and more.

1. To download the Zendure app, scan the QR code or search "Zendure" in the Apple App Store® or Google Play Store.
2. Open the Zendure app. Log In or sign up.
3. Follow the in-app instructions to add your the Smart Meter 3CT-S/1CT-S.
4. Please update the firmware to the latest version in the settings before using.



7. Maintenance

-  **Risk of Electric Shock:** The Smart Meter 3CT-S/1CT-S device must be removed by a qualified electrician with caution. Before disconnecting any wires, ensure that the circuit is de-energized.

1. Put on Insulating Gloves (Note: Not Included, To Be Provided by Electrician/User)
2. Turn off main circuit protection switches to avoid electric shock risk
3. Remove Current Transformers:
 - Remove CT Clamps from the home's circuits
 - Disconnect them from the CT Connector on the Smart Meter 3CT-S/1CT-S
4. Disconnect Power Wires:
 - Remove Live Wires connecting between the Smart Meter 3CT-S/1CT-S and home circuit breaker
 - Remove Neutral Wire (N) connecting between the Smart Meter 3CT-S/1CT-S and home circuit breaker
5. Unmount Device: Remove the Smart Meter 3CT-S/1CT-S from the DIN rail

8. Technical Specifications

| Item | Specification |
|-----------------------|---|
| Product Name | Zendure Smart Meter 1CT-S / 3CT-S |
| Model | 1CT-S: ZDC2502 3CT-S: ZDC2503 |
| SKU | 1CT-S: ZDC2502-wh-eu 3CT-S: ZDC2503-wh-eu |
| Number of CT Clamps | 1CT-S: 1 3CT-S: 3 |
| AC Rated Input | 230V~, 50/60Hz |
| Rated Power | 3W Max. |
| Max. Measured Voltage | 265 VAC |
| Max. Measured Current | 120A per channel |
| Measurement Category | CAT III |
| Wireless Information | Bluetooth: Bluetooth 5.0, 2402–2480 MHz, Max TX Power 20 dBm Wi-Fi: 802.11 b/g/n, 2412–2472 MHz, Max TX Power 20 dBm |